

**Cree® MR16 Series
TrueWhite® LED Lamp**
LED MR16 Lamp



FINALLY, A TRUE LED 50W MR16 REPLACEMENT LAMP

Refined Design & Fit

The MR16's "perfect fit" global design simplifies the task of choosing the optimal lighting solution by providing greater compatibility with existing dimmers and transformers, making the Cree LED MR16 lamp ideal for retail and hospitality applications.

Exceptional Light Quality

Featuring Cree TrueWhite® Technology, the MR16 delivers >90 CRI with high R9 for superior colour quality. Offering a choice of 15°, 25° or 40° beam spreads, Cree's MR16 Series provides targeted light distribution for highlighting merchandise and enhancing the atmosphere of any space.

Remarkable Savings

The Cree MR16 LED lamp provides you with a payback of less than one year, using just 8.7 watts of energy. This impressive combination of greater than 80% energy savings and significant maintenance savings finally delivers a true replacement for halogen MR16 lamps.

CREE 

CREE® MR16 SERIES TRUEWHITE® LED LAMP

At Cree, we're redefining track and accent lighting. Our MR16 LED lamp makes designing the ideal solution for your application quick and easy with a "perfect fit" global design that has greater compatibility with existing dimmers and transformers. Opportunities for greater than 80 percent energy savings that offer a payback of less than one year should make you ask, "Why wait?"

PERFORMANCE SUMMARY

Delivered Light Output: 540 lumens (15D), 580 lumens (25D), 584 lumens (40D)

Input Power: 8.7 watts (50W eq)

CRI: >90

CCT: 3000K

Beam Angle: 15°, 25° and 40°

CBCP: 4648 (15D), 2473 (25D), 1296 (40D)

Limited Warranty: 3 years

Lifetime: Designed to last 25,000 hours

Dimming: 5%

ENERGY STAR® qualified excluding the 540 lumens (15°) version

CONSTRUCTION & MATERIALS

- Durable die-cast aluminum housing with lens protects LEDs and optical system
- Fanless housing design and smart thermal circuit design with embedded intelligent software properly monitors the operating temperature range.
- Slim housing design meets ANSI form factor for halogen lamps.

DIMENSIONS

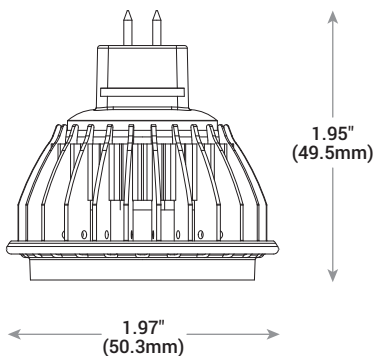

BEAM ANGLES



15° Beam Angle



25° Beam Angle



40° Beam Angle

Visit www.cree.com/canada or contact a Cree lighting representative to learn more

CreeLightingCanada@cree.com | 800.473.1234

© 2014 Cree, Inc. All rights reserved. For informational purposes only. Not a warranty or specification. See www.cree.com/canada/warranty for warranty and specifications. Cree®, the Cree logo, Cree TrueWhite® and the Cree TrueWhite Technology logo are registered trademarks of Cree Inc. ENERGY STAR® and the ENERGY STAR logo are registered trademarks of the U.S. EPA. The UL logo is a registered trademark to UL LLC. CAT/SSHT-C035

